

DC INPUT / DC OUTPUT DISPLACEMENT TRANSDUCERS S-D AND M-D SERIES

The Instruments & Control S-D and M-D series are displacement transducers of LVDT type with self-contained signal conditioners. Their output is a DC voltage proportional to the displacement of the core from its zero position, while the polarity indicates the direction of the displacement.

Some of their features:

- High linearity and stability.
- Negligible sensitivity to supply voltage fluctuation.
- Low output impedance to minimize loading effects.
- Protection against supply polarity reversing.
- Low power consumption, 200 mW typical.
- Infinite resolution: dynamic ranges of better than 100,000:1 are practical.
- All-metal design, including the coil form, for ruggedness and dimensional stability.



SPECIFICATIONS	S-D Series	M-D Series
Linearity	0.25%FR typ ¹⁾	0.15%FR typ.
Input	±15V nominal, 13.5 to 16.5V range, 8 mA typ.	
Output	±5 VDC F.S.	
Output impedance	Less than 10 Ω	
Minimum load resistance	100 Ω	
T. C. of zero	0.01% F.R./°C typ. (0° to 70°C)	
T. C. of scale factor	0.03% /°C typ. (0° to 70°C)	
Operating temperature range	-25°C to 85°C	
Survival temperature range	-55°C to 95°C	
Frequency response	0 to 100 Hz, ±3 db	
Ripple	Less than 0.25% F.S., 5KHz typ.	
Shock survival	250g, 11ms	
Vibration	20g, up to 2 KHz	
Housing material	400 series Stainless Steel	300 series Stainless Steel
Lead wires	#28 AWG plated, stranded copper, Teflon insulated, 12" long (300 mm)	

1) For model S10, the linearity is 0.5%F.R.

BLOCK DIAGRAM OF S-D AND M-D LVDT'S

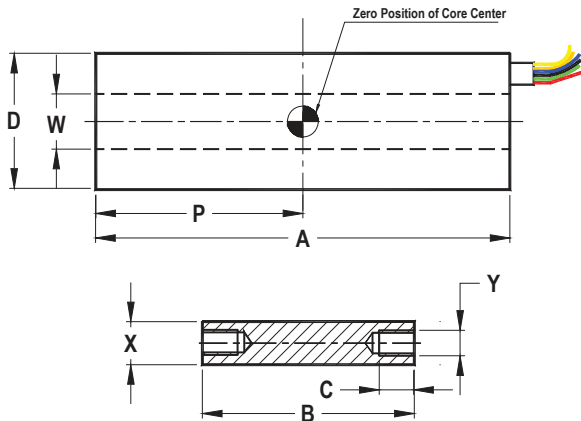
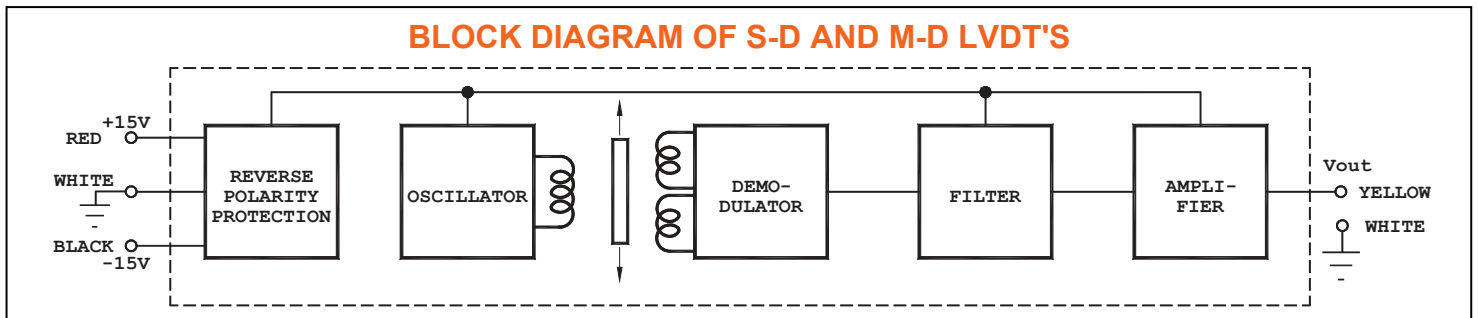

NOTE: Output will be positive when core moves from zero toward lead wires end of LVDT

	S-D Series		M-D Series	
	inches	mm	inches	mm
D	0.750(+0.008, -0.004)	19(+0.20, -0.10)	0.750±0.005	19±0.13
W	0.303±0.008	7.7±0.2	0.148±0.004	3.75±0.10
X	0.235±0.005	6.0±0.10	0.110±0.005	2.8±0.10
Y	#4-40 UNF-2B	M3x0.5-6H	#1-72 UNF-2B	M2x0.4-6H
C	0.4min	10 min	0.3min	7.5min

S – D Series:

MODEL	LINEAR RANGE		DIMENSIONS						CORE WEIGHT Grams
			A		B		P		
	inches	mm	inches	mm	inches	mm	inches	mm	
S.1 D	±0.100	±2.5	2.40	61	0.80	20	0.60	15	4
S.2 D	±0.200	±5.0	3.60	91	1.71	43	1.20	30.5	8
S.5 D	±0.500	±12.5	5.50	140	3.0	76	2.15	55	14
S1 D	±1.000	±25.0	6.70	170	3.3	84	2.75	70	16
S2 D	±2.000	±50.0	12.00	305	6.45	164	5.40	137	30
S5 D	±5.000	±125.0	23.70	602	11.60	295	11.25	286	55
S10 D	±10.000	±250.0	37.20	945	22.0	559	18.00	457	104

M – D Series:

M.02 D	±0.020	±0.5	0.95	24.1	0.375	9.5	A/2	0.3
M.05 D	±0.050	±1.25	0.95	24.1	0.575	14.6	A/2	0.5
M.1 D	±0.100	±2.5	1.20	30.5	0.720	18.3	A/2	0.7
M.2 D	±0.200	±5.0	2.10	53.3	1.425	36.2	A/2	1.3
M.5 D	±0.500	±12.5	3.50	88.9	1.830	46.5	A/2	1.7
M1 D	±1.000	±25.0	5.00	127	2.700	68.6	A/2	2.5

All specifications subject to change without notice.